

**Modular Cooking Range Line
thermaline 90 - 900 mm Passthrough
open base, 2 Sides (H2) - H=550**

ITEM # _____

MODEL # _____

NAME # _____

SIS # _____

AIA # _____



589325 (MC2ADCIOOO)

Passthrough open base,
two-side operated - H2**Short Form Specification****Item No.** _____

900 mm wide open passthrough base compartment to store pots, pans, sheet pans, etc. with hygienic design and round edges. Unit constructed according to DIN 18860_2 with 70 mm recessed plinth. Internal frame for heavy duty sturdiness in 2 mm and 3 mm in 1.4301 (AISI 304). 2 mm top in 1.4301 (AISI 304). Flat surface construction, easily cleanable. THERMODUL connection system enables seamless worktop when units are connected and avoids soil penetrating.

IPX5 water resistant certification.

Configuration: Two-side operated freestanding base, hygienic class H2.

Main Features

- Open base compartment for storage of pots, pans, sheet pans, etc.
- All major components may be easily accessed from the front.
- Unit to be placed below modular top appliances to store pots, pans, sheet pans, etc.

Construction

- Hygienic design of the open base compartment with large round edges.
- IPX5 water resistance certification.
- 2 mm top in 1.4301 (AISI 304).
- Flat surface construction with minimal hidden areas to easily clean all surfaces
- Internal frame for heavy duty sturdiness in stainless steel.

APPROVAL: _____

Front

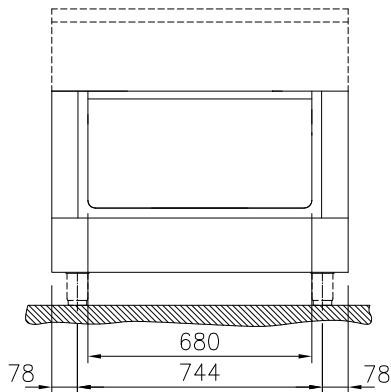

Key Information:

External dimensions, Width:	
589325 (MC2ADCIOOO)	900 mm
External dimensions, Depth:	900 mm
External dimensions, Height:	550 mm
Cupboard Cavity Dimensions (width):	680 mm
Cupboard Cavity Dimensions (height):	330 mm
Cupboard Cavity Dimensions (depth):	860 mm
Net weight:	25 kg

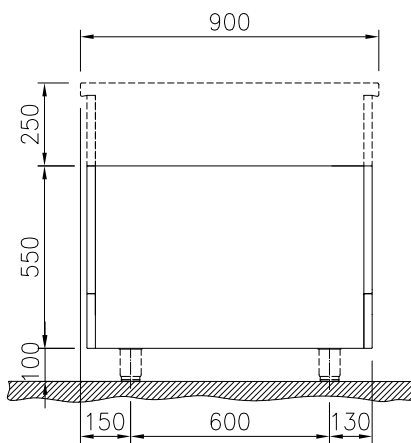
Side

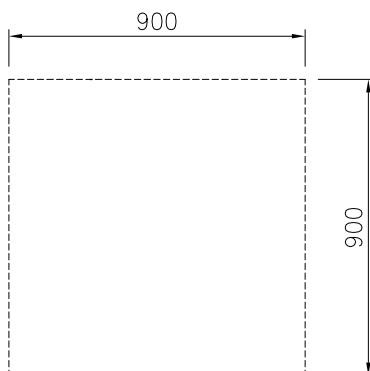

Top



Optional Accessories

- Stainless steel side panel, 900x800mm, freestanding PNC 912511
- Stainless steel front kicking strip, 900mm width PNC 912599
- Stainless steel side kicking strips left and right, freestanding, 900mm width PNC 912621
- Stainless steel plinth, freestanding, 900mm width PNC 912921
- - NOT TRANSLATED - PNC 913238
- - NOT TRANSLATED - PNC 913259
- - NOT TRANSLATED - PNC 913284
- STAINLESS STEEL DIVIDING PANEL 900X800MM LEFT/RIGHT PNC 913673
- STAINLESS STEEL SIDE COVER PANEL, FLUSH 900X800MM LEFT/RIGHT PNC 913689